

LP3972 USB Evaluation Board REV B/5x5

National Semiconductor
Application Note 1621
Sheldon Mah
May 2007



General Description

The LP3972 Flex PMU is a complete power management IC designed for advanced processors. It contains 5 low noise low dropout regulators, 3 DC/DC buck converters, a backup battery charger, real time clock supply regulator [RTC], 2 GPO's and high speed I²C serial interface to program individual regulator output voltages as well as offer on/off control. This USB evaluation board features independent USB powering, virtual voltmeter bank all in a compact demonstration platform.

Key Features

- 2.7V to 5.5V input voltage range
- Programmable V_{OUT} 0.8–3.3 volts
- Up to 95% efficiency
- ±3% output voltage accuracy
- 1.5A output current [bucks]

Applications

- Personal Media Players
- Smart Phones
- PDA Phones
- Digital Cameras

LP3972 Evaluation Board Version B

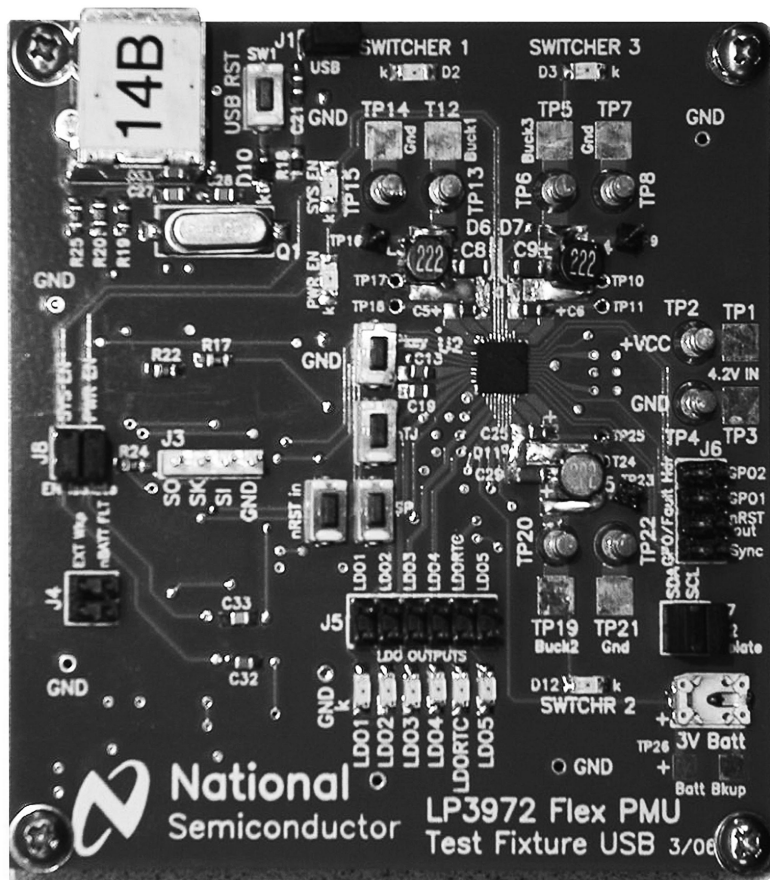

30018301

Evaluation Board/Kit Overview

The LP3972 Evaluation Board supports complete functional evaluation of the power management IC. The functions of the chip are controlled by the I²C interface. The I²C interface on the rev B and later USB boards are driven via a COP8 microprocessor which supports a connection via the USB port and offers chip powering and virtual software voltage measurement of all regulators. In addition, the LP3972 can be powered directly through the USB port for full function. If high current Buck testing is desired, an external LI ION cell or PS capable of supplying 2 amps or more will need to be connected to the appropriate connector.

The evaluation board/kit consists of:

- LP3972 Flex_PMU device soldered down in LQA-40 pin 5X5 LD package

- Full USB interface
- LED LDO monitoring with current limit resistors [selectable]
- External power LDO, Buck output and main battery/supply connectors offered in heavy duty turret pins and solder pads
- Socket for back-up battery
- Users guide
- Codeloader Software version .202 or greater [may be sent via email]

LP3972 Flex_PMU USB Evaluation Board Block Operational Diagram

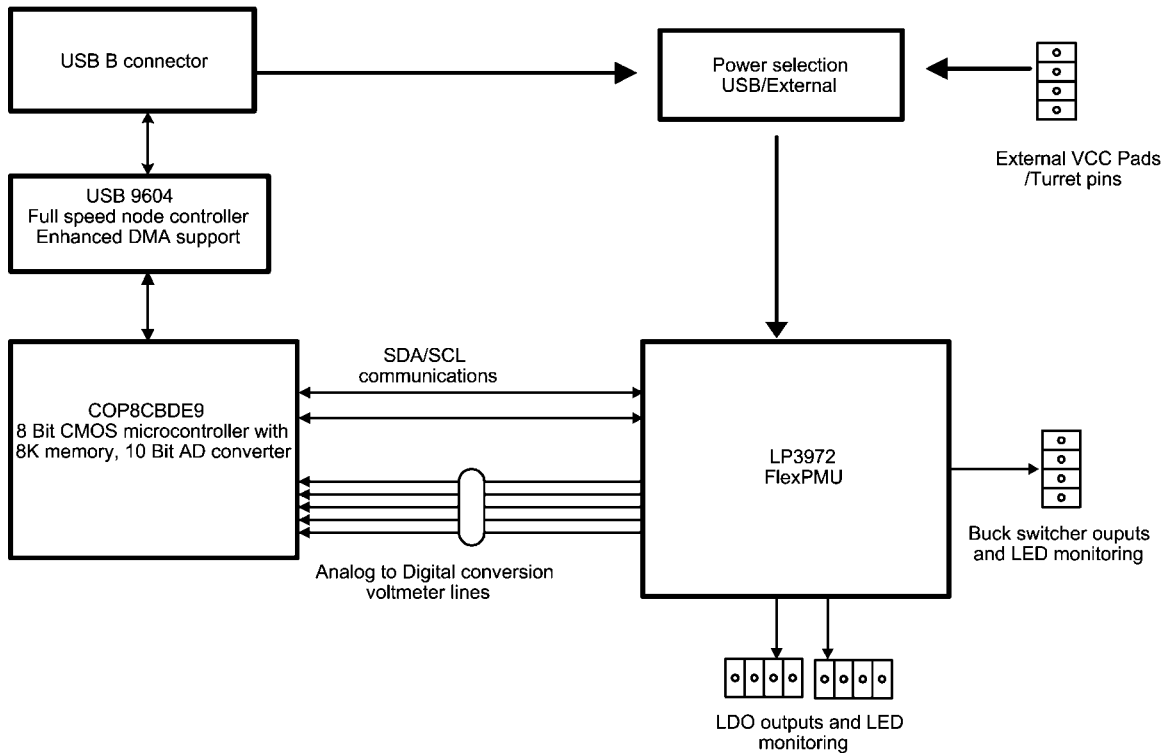

30018302

Pin Description 5X5 package

Pin #	Name	I/O	Type	Description
1	PKEY	I	D	CPU Wakeup Input
2	nTJ	I	D	CPU Wakeup Input
3	SP	I	D	CPU Wakeup Input
4	EXT_WAKEUP	O	D	CPU Wakeup Input
5	FB1, Feedback Buck1	I	A	Buck 1 Feedback
6	$V_{IN1} = V_{BATT}$	I	P	Battery Input for Powering Internal Circuits and LDO1-3
7	LDO_V _{OUT-1}	O	P	LDO1 Output
8	LDO_V _{OUT-2}	O	P	LDO2 Output
9	nRST In	I	D	Chip Reset Input
10	LDO GND 1	G	G	Ground
11	LDO V _{REF} Bypass	O	A	Bypass Capacitor for Reference
12	LDO_V _{OUT-3}	O	P	LDO3 Output
13	LDO_V _{OUT-4}	O	P	LDO4 Output
14	V_{IN} LDO_4	I	P	Input Power for LDO4
15	Back-Up Battery V_{IN}	I	P	Back Up Battery Input
16	LDO_V _{OUT-0} (RTC)	O	P	LDO_RTC Output
17	nBatt_FLT	O	D	Main Battery Fault Output
18	PGND Buck2	G	G	Ground
19	V _{OUT} Buck2	O	P	Buck Switcher2 Output
20	V_{IN} Buck2	I	P	Buck Switcher 2 Battery Input
21	SDA	I/O	D	I ² C Data Line
22	SCL	I	D	I ² C Clock Input
23	FB2, Feedback Buck2	I	A	Buck Switcher 2 Feedback
24	nRST Out	O	D	Reset Output
25	LDO_V _{OUT-5}	O	P	LDO5 Output
26	V_{IN2} (LDO 5 Only)	I	P	Battery Input Power for LDO5
27	VDDA	I	P	Analog Power Input
28	FB3, Feedback Buck3	I	A	Buck Switcher 3 Feedback
29	GPIO1/nCHG_EN	I/O	D	General Purpose I/O #1/BUBATT Charger EN
30	GPIO2	I/O	D	General Purpose I/O #2
31	V_{IN} Buck3	I	P	Buck Switcher 3 Battery Input
32	V _{OUT} Buck3	I	P	Buck Switcher 2 Output
33	PGND Buck3	G	G	Buck3 NMOS Power Ground
34	Buck 1 2 & 3 AVSS/NCHBLK	G	G	Buck1, 2, 3 Analog Ground
35	SYNC (Buck Clock input)	I	D	Buck Switcher External Clock Input
36	Sys_En	I	D	Power Domain Enable
37	Pwr_En	I	D	Power Domain Enable
38	PGND Buck1	G	G	Buck1 NMOS Power Ground
39	V _{OUT} Buck1	O	P	Buck Switcher 1 Output
40	V_{IN} Buck1	I	P	Buck Switcher 1 Battery Input

A: Analog Pin

D: Digital Pin

G: Ground Pin

P: Power Pin

I: Input Pin

I/O: Input/Output Pin

O: Output Pin

Operating Instructions

The following instructions give general instructions for use of LP3972 with the evaluation board. Practice standard ESD protection (ground cable) to prevent any unwanted damaging ESD events.

1. Check that the jumpers are in default settings (jumpers are introduced later in this document).
2. Load version .202 or later of the codeloader program into PC.
3. Connect the USB cable [standard USB AB cable] from the USB connector to PC port.
4. Open the codeloader program up, verify that "USB" port has been selected.
5. Verify that successful communications link has been established by toggling "READ ALL".
6. If there is no communication, key the USB RST [SW1] switch once on the board for reboot.
7. If the voltmeter monitoring function is desired, select "POLL STATUS".
8. LDO/buck outputs may be monitored directly off the appropriate header output pins.
9. Note that for full load testing, an external PS must be connected to TP1/TP2 and jumper J1 must be removed. This is because the USB port source spec is limited to 500 mA and removing the jumper will disconnect the USB supply.
10. PWR EN/SYS En is selectable via codeloader software assignment.
11. Hardware reset can be accomplished by pressing the nREST_In momentary switch.
12. Battery backup is possible by inserting appropriate rechargeable cell into supplied holder.
13. Switches PKEY, nTJ, and SP, are provided for use in normal evaluation mode.

List of Components

Feb. 8, 2007

Item	Qty.	Reference	Value	Pkg.	Manuf.	Part Number
1	5	C1,C21,CC,CD,CF1	10 μ F	0805	Panasonic	ECJ2FF1A106Z
2	2	C2,C3	100 μ F	3528-21	Kemet	T520B107M006ASE040
3	8	C4,C7,C13,C15,C16,C31,CA, CB	1 μ F	0805	Kemet	C0805C105K4RACTU
4	6	C5,C6,C8,C9,C25,C29	10 μ f	1206	Taiyo-Yuden	JMK316BJ106M
5	6	C14,C19,C20,C23,C24,C26	0.47 μ F	0805	TDK	C2012X7R1E474K
6	2	C17,C18	47 pF	0805	Murata	GRM2195C2A470JZ01D
7	4	C22,C30,C32,C33	0.1 μ F	0805	Murata	GRM21BR71E104KA01L
8	2	C27,C28	15 pF	0805	Yageo	0805CG150J9B200
9	1	BT2	Battery Holder	SMT	Seiko	BH0414
10	1	NOT INSTALLED	Backup Battery	Micro4	Seiko	MS412F
11	4	D6,D7,D10,D11	Schottky	PM 457	On Semi	MBRM120LT3
12	2	D8 (PWR EN), D9 (SYS EN)	Green LED	1206	Lumex	SML-LX1206GC-TR
13	9	LDO1(D13), LDO2(D14), LDO3(D18), LDO4(D17), LDO5(D19), LDORTC(D16) D2,D3,D12	Red LED	1206	Lumex	SML-LX1206IC-TR
14	2	L1,L2	1 μ H Inductor	0805	TDK	MLF2012A1R0K
15	3	L3,L4,L5	2.2 μ H Inductor	SMT	Toko	FDSE0312
16	1	Q1	XTAL 24 MHz 18 PF	SMD	Citizen	HCM49-24.000MABJT
17	7	R1,R2,R23,R31,R32, R33,R34	330 Ω	0805	SEI	807065R330
18	1	R8	100 Ω	0805	NIC	NRC10J101TR
19	1	R9	49.9 Ω	0805	Rohm	MCR10EZH49R9
20	11	R10,R11,R12,R17,R18,R22, R24,R26,R27,R36,R37	10K	0805	Yageo	9C08052A1002FKHFT
21	1	R12	0 Ω	0805	Yaego	9C08052A0R00JLHFT
22	4	R15,R16,R28,R29	133 Ω	0805	Rohm	MCR10EZH1330
23	2	R19,R20	22.1 Ω	0805	Vishay-Dale	CRCW080522R1ERT1
24	1	R21	1M	0805	Yageo	9C08052A1004JLHFT
25	1	R25	1.5K	0805	Yageo	9C08052A1501FKHFT

Item	Qty.	Reference	Value	Pkg.	Manuf.	Part Number
26	1	D1	45.3Ω	0805	Vishay-Dale	CRCW080545R3F100
27	5	S1,S2,S3,S4,SW1	Touch Switch	SMD	Panasonic	EVQ-PJU04K
28	1	U1	3.3V Regulator	SOT-23 5	NSC	LP2981AIM5-3.3
29	1	U2	PMU	SQF-40	NSC	LP3972
30	1	U3	USB Controller	SOIC 28	NSC	USBN9604-28M
31	1	U4	Microcontroller	TSSOP 48	NSC	COP8CBE9IMT9
32	1	U5	2V Regulator	SOT-23 5L	NSC	LP3984IMF-2.0
33	1	U6	Voltage Converter	SOT-23-6	NSC	LM2664M6
34	1	J1	100 mil Header	2 pos	Amp	1 X 2 (4-103239-0-02)
35	1	J2	USB Receptacle	4 pos	FCI	61729-0010B
36	1	J3	100 mil Header	4 pos	Molex	1 X 4 (22-10-2041)
37	3	J4,J7,J8	100 mil Header	4 pos	Amp	2 X 2 (4-103240-0-02)
38	1	J5	100 mil Header	12 pos	Amp	2 X 6 (4-103240-0-06)
39	1	J6	GPO/LDO Headers	8 pos	Amp	2 X 4 (4-103186-0-04)
40	9	TP9,TP10,TP11,TP16, TP17,TP18,TP23,TP24,TP25	Test Points	1 pos	Amp	1 X 1 (4-103185-0-01)
41	8	TP2,TP4,TP6,TP8,TP13, TP15,TP20,TP22	Turret Terminal	0.109"L	Keystone	1502-2
42	1	LP3972 version B Fab	Bare board	4 Layer	Rainbow Labs	LP3972-B

Powering and Jumpers Selection

The LP3972 USB evaluation platform offers several power connectors. These connectors are outlined on the table below. In addition, the Evaluation board has jumpers for special

modes and stand-alone use. The default jumper settings are valid in normal operation and are also outlined below.

Component	Use	Comment
J5-1	Output for LDO1	Outside Pin of Connector is Grd
J5-2	Output for LDO2	Outside Pin of Connector is Grd
J5-3	Output for LDO3	Outside Pin of Connector is Grd
J5-4	Output for LDO4	Outside Pin of Connector is Grd
J5-6	Output for LDO5	Use LED Pad [Missed Pin]
J5-5	Output for RTC [Real time Clock]	Outside Pin of Connector is Grd
J4-1	Input for external wakeup	Outside Pin of Connector is Grd
J4-2	Output for nBATT Fault	Outside Pin of Connector is Grd
J6-2	Output for nREST	Outside Pin of Connector is Grd
J6-3	GPO 1 output	Outside Pin of Connector is Grd
J6-4	GPO 2 output	Outside Pin of Connector is Grd
J3-1	Cop8 microwire SO	Used for Micro Flash Only
J3-2	Cop8 microwire SK	Used for Micro Flash Only
J3-3	Cop8 microwire SI	Used for Micro Flash Only
J3-4	Cop 8 Grd	Used for Micro Flash Only
TP14-15	Output for switcher buck 1	GRD is TP12-13
TP19-20	Output for switcher buck 2	GRD is TP21-22
TP5-6	Output for switcher buck 3	GRD is 7-8
USB	USB connector	Connect to PC via Supplied Cable
J1	Power usage selection	Place Jumper for USB, NO JUMPER for External Power Input
TP1-2	Connect external V_{CC} supply here 3.5-5 volts for high current testing	Doubles for LI-ION Cell Input, Select Appropriate J1 Setting [2-3]

Demonstration Software Window

The demonstration software enables read and write to LP3972's internal registers through PC's USB port. All the user controllable registers are usable through the software.

Installation: Run the codeloader for LP3972 version .202 or greater.

After startup the user can verify that successful USB communication has been established by selecting "Read All", the default programmed voltages should appear.

LDO's can be enabled and disabled by clicking mouse left button on the square close to each LDO voltage slider. Changing the virtual slider changes the LDO voltage. After the WRITE button is pressed subsequent LDO changes are applied if the 'autowrite' feature is disabled.

Note 'Autowrite' enabled is default. In the case of the buck control, an option for 'hold' or 'go' can be selected. Note voltage will not change until the 'go' selection is made.

The virtual voltmeters can be activated by selecting 'Poll Status', after which an A to D conversion is read and displayed for each subsequent LDO and Buck output. Note that this feature is meant to be a general measurement and "may" be subject to variations due to operations noise. Since there is a bi-directional SDA feature, any register and its contents can be determined by entering the desired register address and selecting 'Read'. In addition, any corresponding register may be written directly to via the 'Store' selection. All virtual sliders can be updated via the 'Read All' Tab. Direct register control is possible by entering the desired address and value followed by a 'Store' command.

30018303

Top Trace

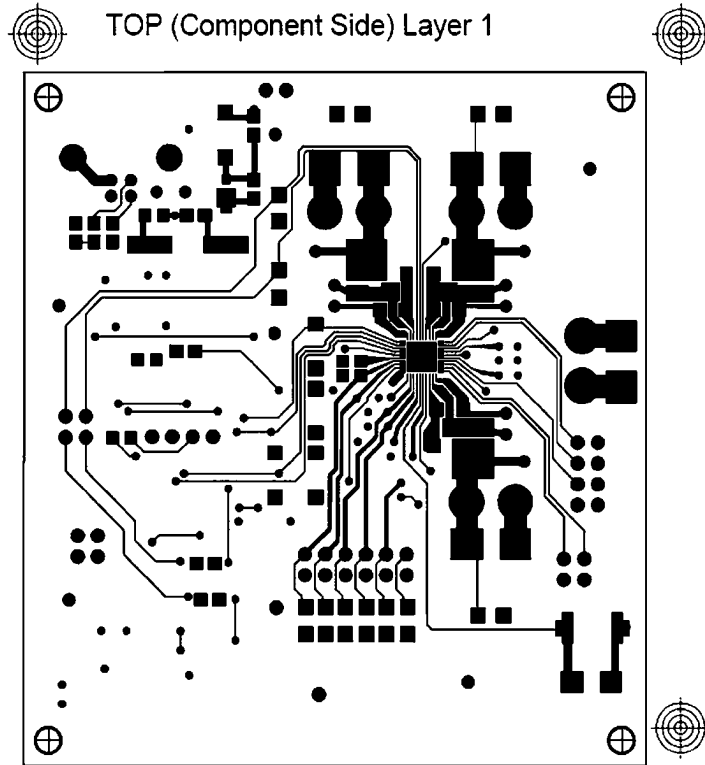

Bottom Trace

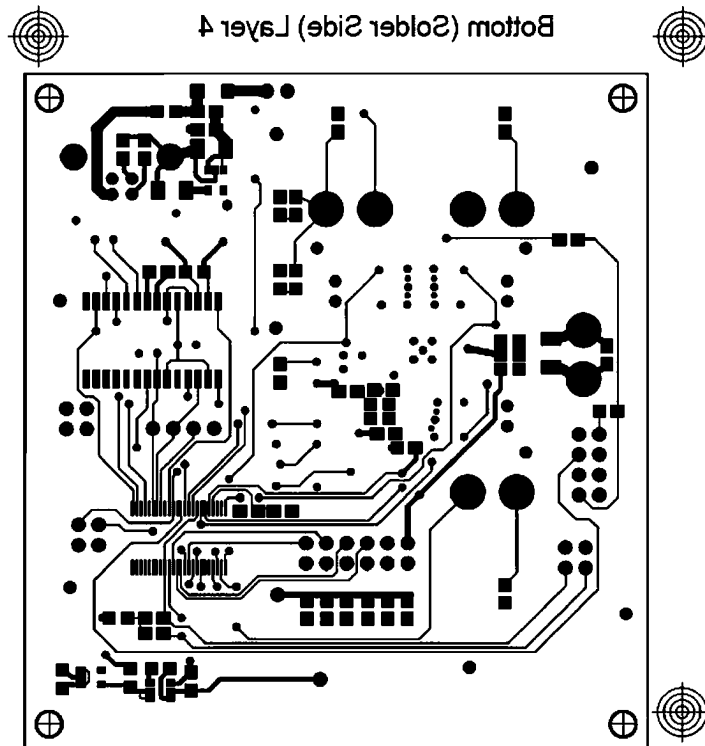

Bottom Silkscreen

BOTTOM SILKSCREEN LEGEND

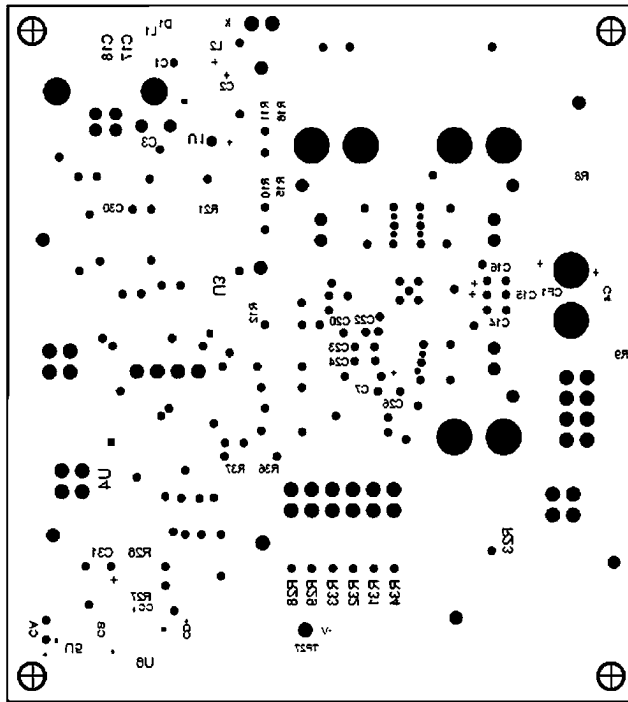

30018308

Ground Plane

GND Layer 2

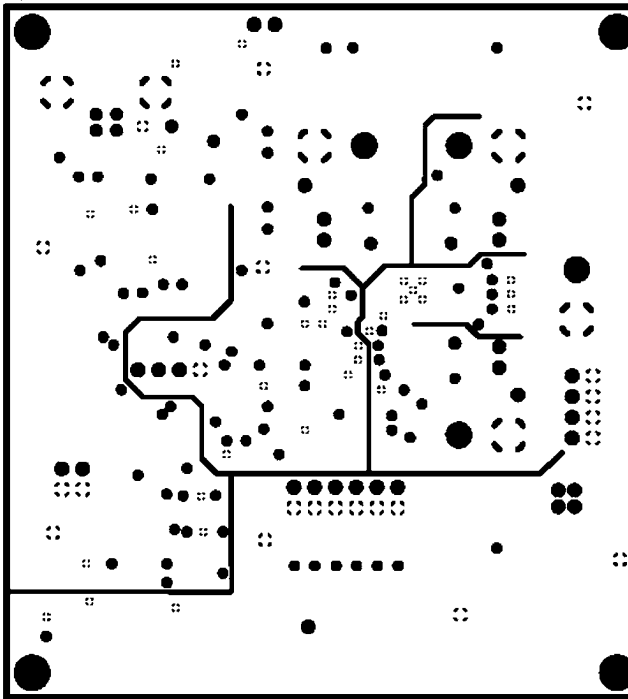

30018309

Power Plane

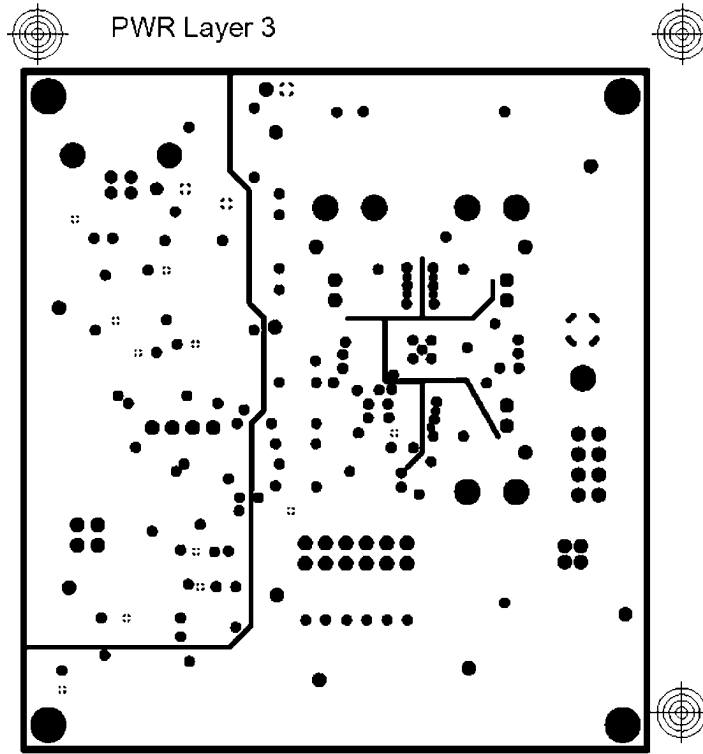

30018310

Bare Board/Component Locations

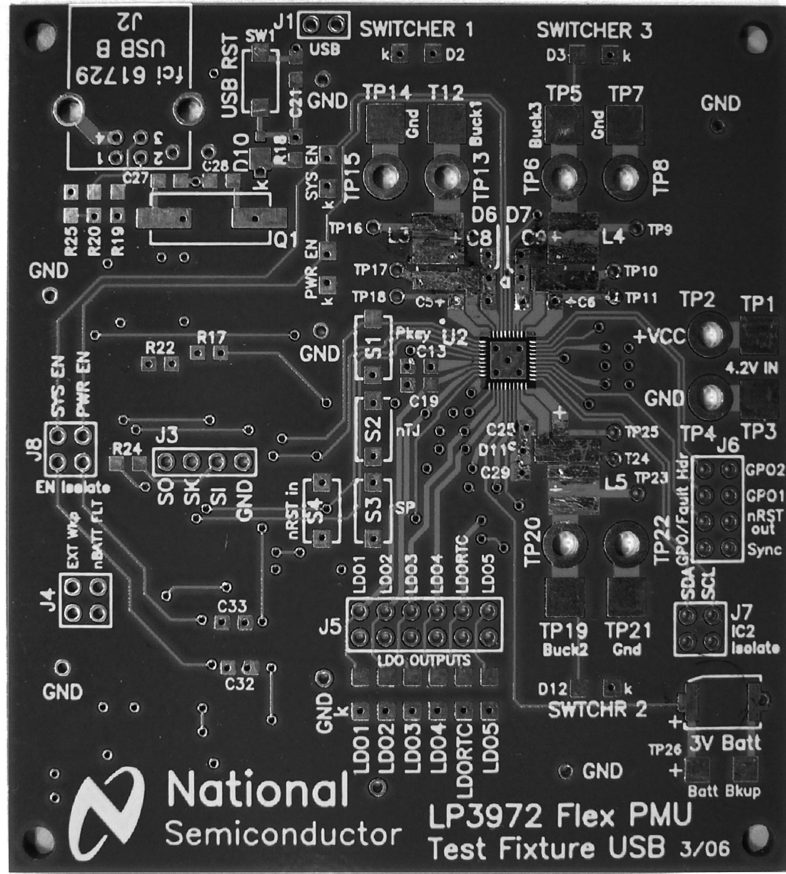

30018311

Notes

AN-1621

Notes

THE CONTENTS OF THIS DOCUMENT ARE PROVIDED IN CONNECTION WITH NATIONAL SEMICONDUCTOR CORPORATION ("NATIONAL") PRODUCTS. NATIONAL MAKES NO REPRESENTATIONS OR WARRANTIES WITH RESPECT TO THE ACCURACY OR COMPLETENESS OF THE CONTENTS OF THIS PUBLICATION AND RESERVES THE RIGHT TO MAKE CHANGES TO SPECIFICATIONS AND PRODUCT DESCRIPTIONS AT ANY TIME WITHOUT NOTICE. NO LICENSE, WHETHER EXPRESS, IMPLIED, ARISING BY ESTOPPEL OR OTHERWISE, TO ANY INTELLECTUAL PROPERTY RIGHTS IS GRANTED BY THIS DOCUMENT.

TESTING AND OTHER QUALITY CONTROLS ARE USED TO THE EXTENT NATIONAL DEEMS NECESSARY TO SUPPORT NATIONAL'S PRODUCT WARRANTY. EXCEPT WHERE MANDATED BY GOVERNMENT REQUIREMENTS, TESTING OF ALL PARAMETERS OF EACH PRODUCT IS NOT NECESSARILY PERFORMED. NATIONAL ASSUMES NO LIABILITY FOR APPLICATIONS ASSISTANCE OR BUYER PRODUCT DESIGN. BUYERS ARE RESPONSIBLE FOR THEIR PRODUCTS AND APPLICATIONS USING NATIONAL COMPONENTS. PRIOR TO USING OR DISTRIBUTING ANY PRODUCTS THAT INCLUDE NATIONAL COMPONENTS, BUYERS SHOULD PROVIDE ADEQUATE DESIGN, TESTING AND OPERATING SAFEGUARDS.

EXCEPT AS PROVIDED IN NATIONAL'S TERMS AND CONDITIONS OF SALE FOR SUCH PRODUCTS, NATIONAL ASSUMES NO LIABILITY WHATSOEVER, AND NATIONAL DISCLAIMS ANY EXPRESS OR IMPLIED WARRANTY RELATING TO THE SALE AND/OR USE OF NATIONAL PRODUCTS INCLUDING LIABILITY OR WARRANTIES RELATING TO FITNESS FOR A PARTICULAR PURPOSE, MERCHANTABILITY, OR INFRINGEMENT OF ANY PATENT, COPYRIGHT OR OTHER INTELLECTUAL PROPERTY RIGHT.

LIFE SUPPORT POLICY

NATIONAL'S PRODUCTS ARE NOT AUTHORIZED FOR USE AS CRITICAL COMPONENTS IN LIFE SUPPORT DEVICES OR SYSTEMS WITHOUT THE EXPRESS PRIOR WRITTEN APPROVAL OF THE CHIEF EXECUTIVE OFFICER AND GENERAL COUNSEL OF NATIONAL SEMICONDUCTOR CORPORATION. As used herein:

Life support devices or systems are devices which (a) are intended for surgical implant into the body, or (b) support or sustain life and whose failure to perform when properly used in accordance with instructions for use provided in the labeling can be reasonably expected to result in a significant injury to the user. A critical component is any component in a life support device or system whose failure to perform can be reasonably expected to cause the failure of the life support device or system or to affect its safety or effectiveness.

National Semiconductor and the National Semiconductor logo are registered trademarks of National Semiconductor Corporation. All other brand or product names may be trademarks or registered trademarks of their respective holders.

Copyright© 2007 National Semiconductor Corporation

For the most current product information visit us at www.national.com



**National Semiconductor
Americas Customer
Support Center**
Email:
new.feedback@nsc.com
Tel: 1-800-272-9959

**National Semiconductor Europe
Customer Support Center**
Fax: +49 (0) 180-530-85-86
Email: europe.support@nsc.com
Deutsch Tel: +49 (0) 69 9508 6208
English Tel: +49 (0) 870 24 0 2171
Français Tel: +33 (0) 1 41 91 8790

**National Semiconductor Asia
Pacific Customer Support Center**
Email: ap.support@nsc.com

**National Semiconductor Japan
Customer Support Center**
Fax: 81-3-5639-7507
Email: jpn.feedback@nsc.com
Tel: 81-3-5639-7560